



Ball Screws

Precision ground



A.MANNESMANN
A member of
SCHNEEBERGER linear technology

Our ground positioning ball screws are mainly used in highly demanding applications such as machine tools or measuring and testing machines. The precision ground ball contact surfaces deliver high positioning and repeat accuracy. This means, the path distance can be measured via the spindle. Furthermore, these ball screws operate smoothly and hold constant torque.

Areas of application for ground ball screws

- Machine tools
- Process machines
- General mechanical engineering
- Robotics and automation
- Drive technology
- Plastic injection molding machines
- Measuring and testing technology

Features

- Induction hardened spindle
- Ball track hardness of 60 ± 2 HRC
- Nut through-hardened in salt bath

Ground ball track on spindle

- Smooth and low noise running behavior
- Minimum wear

Ground spindle outer diameter

- Improved sealing efficiency of the wiper systems
- Ground in same clamping with bearing seats

Ground ball track on nut

- Minimal heat generation
- Smooth running behavior
- Minimum wear

Ground bearing seat on nut

- Optimal positional tolerance

Ground bearing seats

- Perfect bearing fit

Internal ball recirculation

- Low noise
- No interfering contours
- Protected ball return

Non interrupted mounting shoulder

- Bearings with maximum possible internal diameter
- Optimal connection of fixed bearings

Combinable wiper systems

- Optimal protection for the inside of the nut
- Supports long-life cycle
- Reduces lubricant loss



Performance parameters	Double nut (DSF)	Single nut (ESF)
Spindle diameter in mm	Ø 32..., Ø 40..., Ø 50..., Ø 63...	
Max. thread length in mm	2'000	
ISO accuracy class - Type P	IT 3 (V 300p: 12 µm)	
Max. speed in m/min.	100	65
Max. acceleration in m/s ²	15 (1.5g)	6 (0.6g)
Nut preload	2-point (7% C _{dyn})	4-point (5% C _{dyn})

Double nut with 2-point O-preload

- Preload adjustment via alignment of flange nut to locknut by means of a ground feather key
- Steady low idling torque with high rigidity
- High-precision positioning, even at low speeds and oscillating short-stroke movements
- 2-point ball contact results in better efficiency compared to 4-point ball contact
- The best technical solution, minimum heat generation and minimum wear

Single nut with 4-point X-preload

- Single nuts are preloaded via ball sorting in 4-point ball contact between nut and spindle
- Compact design requires a shorter spindle length compared to a double nut with the same stroke
- Due to production tolerance, single nuts are mainly used for shorter ball screws
- With single nuts, impermissibly complete ball reliefs cannot result even at load peaks
- Ball screws with single nuts can be manufactured more economically than double nuts

Wiper systems



Brush wiper BW

- For normal loads
- Length dimension, l₂ (standard)
- Very compact design
- Completely integrated into the nut body



Finger wiper FW

- High-performance seal for heavy stresses
- Length measurement, l₂ + 20 mm
- Sealing lip is adapted to the profile geometry
- Optimal sealing efficiency due to ground spindle outer diameter



Double wiper DW

- Combination of brush wiper and finger wiper
- Length dimension, l₂ + 20 mm

Ordering information

Ball screw	10	SBS	-32 x 5 x 3.5	-1200	-1400	-P3R	-DSF	-B	-BW	-TT-PT-ST
Quantity										
Product	SBS									
Size	32..., 40..., 50..., 63...									
Thread length	up to 2'000 mm									
Total length	up to 2'300 mm									
Spindle type	P3R									
Design of nut	Double Nut (DSF), Single Nut (ESF)									
Flange shape	Shape (A), Shape (B)									
Wipers	Brush Wiper (BW), Finger Wiper (FW), Double Wiper (DW)									
Documentation	Torque Test (TT), Pitch Test (PT), Stiffness Test (ST)									

Technical data double nut

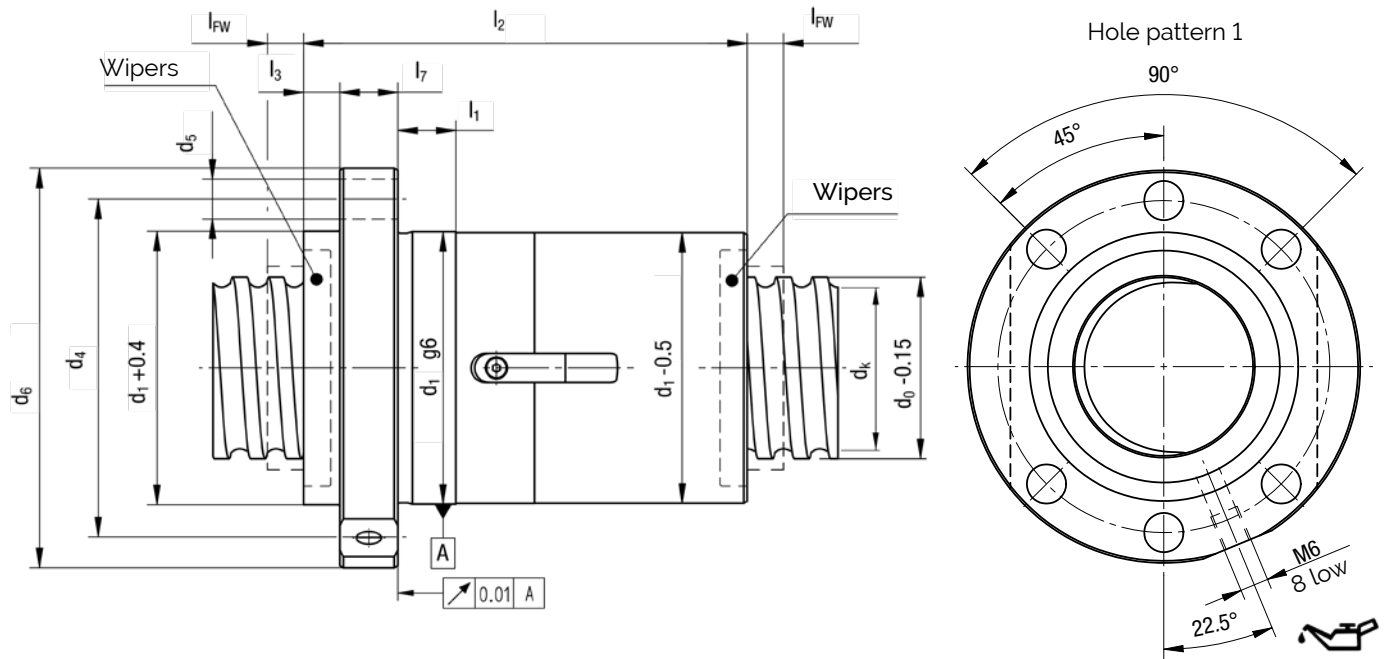

Product	Dynamic load capacity	Static load capacity	Max. speed	No. of nut circuits	Nominal Ø	Pitch	Ball Ø
Size	C_{dyn} [N]	C_0 [N]	n_{max} [min ⁻¹]	i	d_0 [mm]	P [mm]	d_B [mm]
32 x 5 x 3,5 - DSF	28'000	53'000	4'100	5	32	5	3.5
32 x 10 x 3,5 - DSF	24'000	43'000	4'100	4	32	10	3.5
32 x 10 x 6 - DSF	57'000	96'000	4'100	4	32	10	6
32 x 15 x 6 - DSF	50'000	76'000	4'100	3	32	15	6
32 x 20 x 6 - DSF	36'000	49'000	4'100	2	32	20	6
40 x 5 x 3,5 - DSF	35'000	76'000	4'000	6	40	5	3.5
40 x 10 x 6 - DSF	64'000	124'000	4'000	4	40	10	6
40 x 15 x 6 - DSF	69'000	123'000	4'000	4	40	15	6
40 x 20 x 6 - DSF	55'000	92'000	4'000	3	40	20	6
40 x 20 x 8 - DSF	80'000	125'000	4'000	3	40	20	8
40 x 25 x 6 - DSF	40'000	59'000	4'000	2	40	25	6
40 x 25 x 8 - DSF	58'000	80'000	4'000	2	40	25	8
50 x 5 x 3,5 - DSF	38'000	92'000	3'200	6	50	5	3.5
50 x 10 x 6 - DSF	85'000	194'000	3'200	5	50	10	6
50 x 15 x 6 - DSF	92'000	194'000	3'200	5	50	15	6
50 x 15 x 8 - DSF	111'000	205'000	3'200	4	50	15	8
50 x 20 x 6 - DSF	78'000	156'000	3'200	4	50	20	6
50 x 20 x 8 - DSF	111'000	205'000	3'200	4	50	20	8
50 x 25 x 8 - DSF	89'000	152'000	3'200	3	50	25	8
50 x 30 x 6 - DSF	45'000	75'000	3'200	2	50	30	6
50 x 30 x 8 - DSF	64'000	98'000	3'200	2	50	30	8
63 x 10 x 6 - DSF	106'000	284'000	2'600	6	63	10	6
63 x 15 x 8 - DSF	150'000	328'000	2'600	5	63	15	8
63 x 15 x 10 - DSF	201'000	414'000	2'600	5	63	15	10
63 x 20 x 8 - DSF	150'000	327'000	2'600	5	63	20	8
63 x 20 x 10 - DSF	200'000	413'000	2'600	5	63	20	10
63 x 25 x 8 - DSF	127'000	263'000	2'600	4	63	25	8
63 x 25 x 10 - DSF	169'000	331'000	2'600	4	63	25	10
63 x 30 x 8 - DSF	102'000	196'000	2'600	3	63	30	8
63 x 30 x 10 - DSF	136'000	246'000	2'600	3	63	30	10

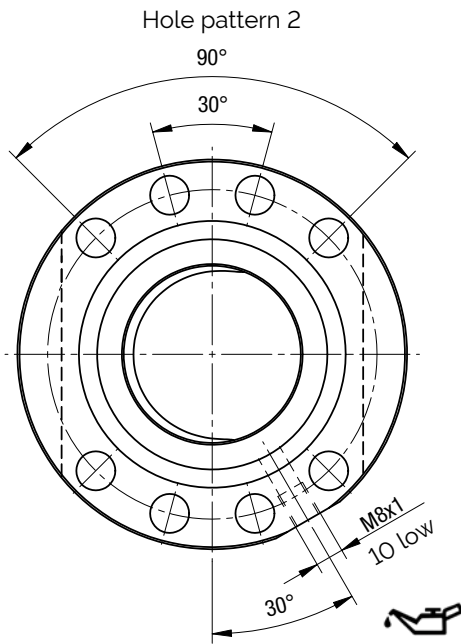

Flange shape A

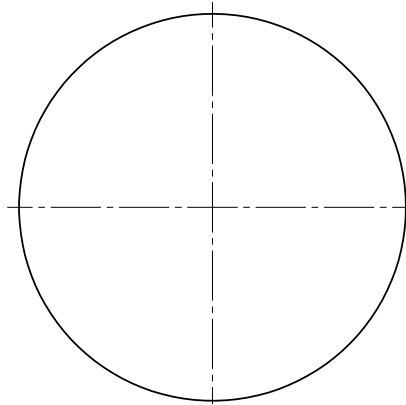

Flange shape B

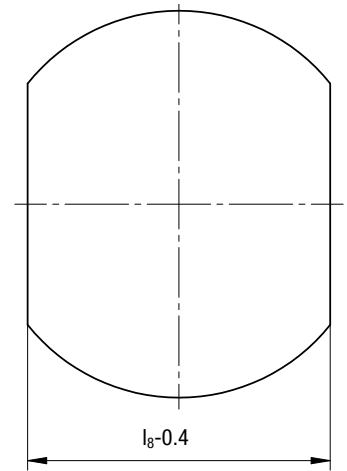

Spindle Core Ø	Further Ø measurements				Distance measurements							Flange	
	d _k [mm]	d ₁ [mm]	d ₄ [mm]	d ₅ [mm]	d ₆ [mm]	l ₁ [mm]	l ₂ [mm]	l ₃ [mm]	l ₇ [mm]	l ₈ [mm]	l _{FW} [mm]	Hole pattern	Shape
28.8	50	65	9	80	10	90	8	12	62	10	10	1	A/B
28.8	50	65	9	80	16	121	8	12	62	10	10	1	A/B
26.3	56	71	9	86	16	127	10	14	65	10	10	1	A/B
26.3	56	71	9	86	20	136	10	14	65	10	10	1	A/B
26.3	56	71	9	86	20	124	10	14	65	10	10	1	A/B
36.8	63	78	9	93	10	99	10	14	70	10	10	2	A/B
34.3	63	78	9	93	16	127	10	14	70	10	10	2	A/B
34.3	63	78	9	93	16	162	10	14	70	10	10	2	A/B
34.3	63	78	9	93	16	166	10	14	70	10	10	2	A/B
32.7	70	85	9	100	25	173	10	14	75	10	10	2	A/B
34.3	63	78	9	93	16	143	10	14	70	10	10	2	A/B
32.7	70	85	9	100	25	152	10	14	75	10	10	2	A/B
46.8	75	93	11	110	10	100	10	16	85	10	10	2	A/B
44.3	75	93	11	110	16	148	10	16	85	10	10	2	A/B
44.3	75	93	11	110	16	197	10	16	85	10	10	2	A/B
42.7	82	100	11	118	25	178	10	16	92	10	10	2	A/B
44.3	75	93	11	110	16	211	10	16	85	10	10	2	A/B
42.7	82	100	11	118	25	213	10	16	92	10	10	2	A/B
42.7	82	100	11	118	25	208	10	16	92	10	10	2	A/B
44.3	75	93	11	110	16	165	10	16	85	10	10	2	A/B
42.7	82	100	11	118	25	170	10	16	92	10	10	2	A/B
57.3	90	108	11	125	16	176	10	18	95	10	10	2	A/B
55.7	95	115	13.5	135	24	209	10	20	100	10	10	2	B
53.7	105	125	13.5	145	30	211	12	20	110	10	10	2	B
55.7	95	115	13.5	135	24	256	10	20	100	10	10	2	B
53.7	105	125	13.5	145	30	259	12	20	110	10	10	2	B
55.7	95	115	13.5	135	24	257	10	20	100	10	10	2	B
53.7	105	125	13.5	145	30	257	12	20	110	10	10	2	B
55.7	95	115	13.5	135	24	243	10	20	100	10	10	2	B
53.7	105	125	13.5	145	30	237	12	20	110	10	10	2	B

Technical data single nut

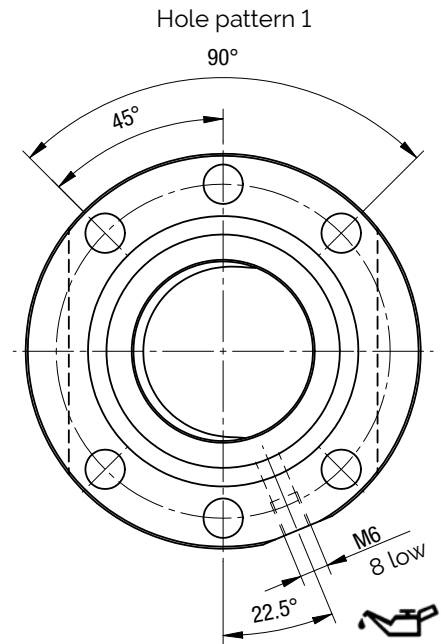
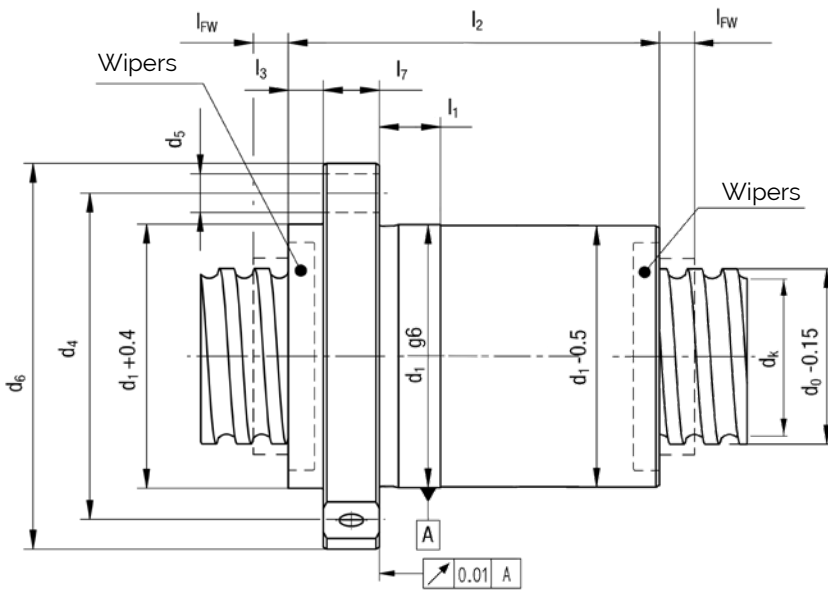

Product	Dynamic load capacity	Static load capacity	Max. speed	No. of nut circuits	Nominal Ø	Pitch	Ball Ø
Size	C_{dyn} [N]	C_0 [N]	n_{max} [min ⁻¹]	i	d_0 [mm]	P [mm]	d_B [mm]
32 x 5 x 3.5 - ESF	29'000	69'000	2'300	5	32	5	3.5
32 x 10 x 3.5 - ESF	24'000	56'000	2'300	4	32	10	3.5
32 x 10 x 6 - ESF	48'000	92'000	2'500	4	32	10	6
32 x 15 x 6 - ESF	46'000	73'000	3'200	3	32	15	6
32 x 20 x 6 - ESF	33'000	47'000	3'200	2	32	20	6
40 x 5 x 3.5 - ESF	35'000	96'000	1'800	6	40	5	3.5
40 x 10 x 6 - ESF	55'000	117'000	1'900	4	40	10	6
40 x 15 x 6 - ESF	62'000	119'000	2'600	4	40	15	6
40 x 20 x 6 - ESF	50'000	88'000	2'600	3	40	20	6
40 x 20 x 8 - ESF	74'000	121'000	2'600	3	40	20	8
40 x 25 x 6 - ESF*	36'000	57'000	2'600	2	40	25	6
40 x 25 x 8 - ESF*	54'000	77'000	2'600	2	40	25	8
50 x 5 x 3.5 - ESF	38'000	118'000	1'400	6	50	5	3.5
50 x 10 x 6 - ESF	71'000	180'000	1'500	5	50	10	6
50 x 15 x 6 - ESF	83'000	187'000	2'100	5	50	15	6
50 x 15 x 8 - ESF	102'000	200'000	2'100	4	50	15	8
50 x 20 x 6 - ESF	70'000	150'000	2'100	4	50	20	6
50 x 20 x 8 - ESF	102'000	199'000	2'100	4	50	20	8
50 x 25 x 8 - ESF*	82'000	148'000	2'100	3	50	25	8
50 x 30 x 6 - ESF*	41'000	73'000	2'100	2	50	30	6
50 x 30 x 8 - ESF*	59'000	95'000	2'100	2	50	30	8
63 x 10 x 6 - ESF*	90'000	268'000	1'600	6	63	10	6
63 x 15 x 8 - ESF*	137'000	319'000	1'700	5	63	15	8
63 x 15 x 10 - ESF*	180'000	389'000	1'700	5	63	15	10
63 x 20 x 8 - ESF*	136'000	318'000	1'700	5	63	20	8
63 x 20 x 10 - ESF*	180'000	389'000	1'700	5	63	20	10
63 x 25 x 8 - ESF*	115'000	256'000	1'700	4	63	25	8
63 x 25 x 10 - ESF*	152'000	311'000	1'700	4	63	25	10
63 x 30 x 8 - ESF*	93'000	191'000	1'700	3	63	30	8
63 x 30 x 10 - ESF*	122'000	231'000	1'700	3	63	30	10

*Available in 2022

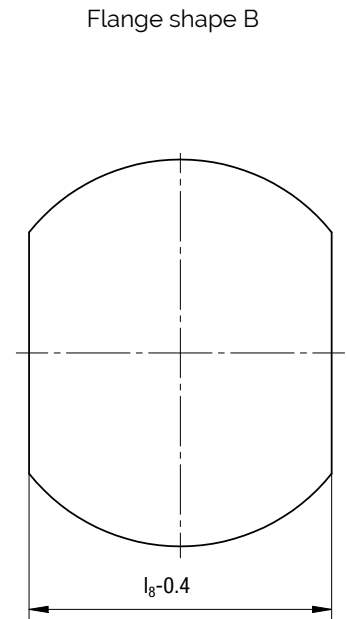
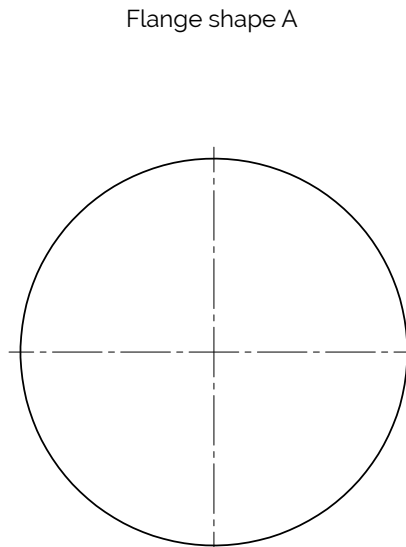
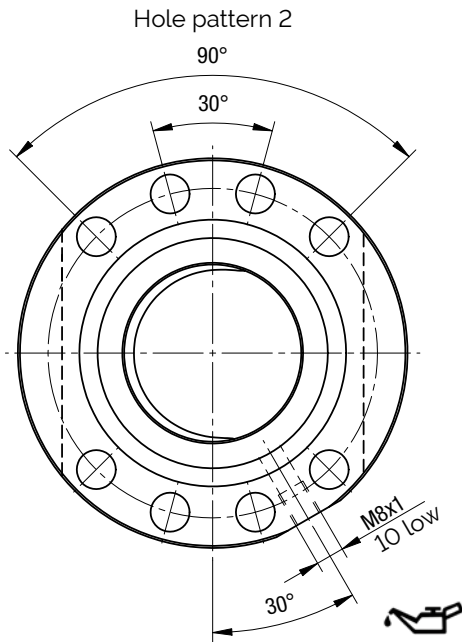

Spindle Core Ø	Further Ø measurements				Distance measurements							Flange	
	d _k [mm]	d ₁ [mm]	d ₄ [mm]	d ₅ [mm]	d ₆ [mm]	l ₁ [mm]	l ₂ [mm]	l ₃ [mm]	l ₇ [mm]	l ₈ [mm]	l _{FW} [mm]	Hole pattern	Shape
28.8	50	65	9	80	10	49	8	12	62	10	1	A/B	
28.8	50	65	9	80	16	63	8	12	62	10	1	A/B	
26.3	56	71	9	86	16	66	10	14	65	10	1	A/B	
26.3	56	71	9	86	20	71	10	14	65	10	1	A/B	
26.3	56	71	9	86	20	67	10	14	65	10	1	A/B	
36.8	63	78	9	93	10	54	10	14	70	10	2	A/B	
34.3	63	78	9	93	16	64	10	14	70	10	2	A/B	
34.3	63	78	9	93	16	86	10	14	70	10	2	A/B	
34.3	63	78	9	93	16	86	10	14	70	10	2	A/B	
32.7	70	85	9	100	25	90	10	14	75	10	2	A/B	
34.3	63	78	9	93	16	76	10	14	70	10	2	A/B	
32.7	70	85	9	100	25	80	10	14	75	10	2	A/B	
46.8	75	93	11	110	10	54	10	16	85	10	2	A/B	
44.3	75	93	11	110	16	74	10	16	85	10	2	A/B	
44.3	75	93	11	110	16	86	10	16	85	10	2	A/B	
42.7	82	100	11	118	25	90	10	16	92	10	2	A/B	
44.3	75	93	11	110	16	106	10	16	85	10	2	A/B	
42.7	82	100	11	118	25	110	10	16	92	10	2	A/B	
42.7	82	100	11	118	25	105	10	16	92	10	2	A/B	
44.3	75	93	11	110	16	86	10	16	85	10	2	A/B	
42.7	82	100	11	118	25	90	10	16	92	10	2	A/B	
57.3	90	108	11	125	16	89	10	18	95	10	2	A/B	
55.7	95	115	13.5	135	24	108	10	20	100	10	2	B	
53.7	105	125	13.5	145	30	111	12	20	110	10	2	B	
55.7	95	115	13.5	135	24	133	10	20	100	10	2	B	
53.7	105	125	13.5	145	30	136	12	20	110	10	2	B	
55.7	95	115	13.5	135	24	133	10	20	100	10	2	B	
53.7	105	125	13.5	145	30	136	12	20	110	10	2	B	
55.7	95	115	13.5	135	24	123	10	20	100	10	2	B	
53.7	105	125	13.5	145	30	126	12	20	110	10	2	B	

SCHNEEBERGER COMPANIES

SWITZERLAND

SCHNEEBERGER AG
Lineartechnik
St. Urbanstrasse 12
4914 Roggwil/BE

+41 62 918 41 11
+41 62 918 41 00
info-ch@schneeberger.com

GERMANY

SCHNEEBERGER GmbH
Gräfenau
75339 Höfen/Enz

+49 7081 782 0
+49 7081 782 124
info-d@schneeberger.com

ITALY

SCHNEEBERGER S.r.l.
Via Soldani 10
21021 Angera (VA)

+39 0331 93 20 10
+39 0331 93 16 55
info-i@schneeberger.com

USA

SCHNEEBERGER Inc.
44 Sixth Road,
Woburn, MA 01801-1759

+1 781 271 0140
+1 781 932 4127
info-usa@schneeberger.com

INDIA

SCHNEEBERGER India Pvt. Ltd.
Office No. 4.20
91 Springboard Business Hub Pvt Ltd
175 & 176, Dollars Colony, Phase 4, JP Nagar,
Bannerghatta Main Road, Banglore,
Karnataka, 560076
India

+91 73 0454 0119
info-in@schneeberger.com

JAPAN

Nippon SCHNEEBERGER K.K.
Crane Toranomon Bldg 7F
3-20-5 Toranomon, Minato-ku
Tokyo 105-0001

日本シュネーベルガー株式会社
〒105-0001
東京都港区虎ノ門3-20-5
クレイン虎ノ門ビル7階

+81 3 6435 7474
+81 3 6435 7475
info-j@schneeberger.com

CHINA

SCHNEEBERGER
(Shanghai) Co., Ltd.
Rm 606, Shang Gao International
Building
No. 137 XianXia Road
200051 Shanghai

施耐博格 (上海) 传动技术有限公司
上海市长宁区
仙霞路137号盛高国
际大厦606室, 上海 200051

+86 21 6209 0027
+86 21 6209 0102
info-cn@schneeberger.com

KOREA

SCHNEEBERGER Korea Ltd.
Garden5 Tool
10, Chungmin-ro,
Songpa-gu, Seoul,
Korea 05840

슈니베르코리아 유통회사
05840 서울시 송파구 중민로 10
가든파인브 톨관 10층

+82 2 554 2971
+82 2 554 3971
info-kr@schneeberger.com

SINGAPORE

SCHNEEBERGER Linear
Technology Pte. Ltd.
38 Ang Mo Kio Industrial
Park 2
#01-04, Singapur 569511

+65 6841 2385
+65 6841 3408
info-sg@schneeberger.com

TURKEY

SCHNEEBERGER LINEER TEKNOLOJİ Tic.
ve Ltd. Şti.
Ataköy 9. Kısım Mah.
Yüzücü Talat Yüzmen Sokak No:6
Yunus Emre Sitesi S3 A-Blok D:2
Bakırköy 34158 Istanbul
Türkei

+90 (0) 216 511 56 55
+90 (0) 545 320 83 55
info-tr@schneeberger.com

SCHNEEBERGER MINERAL CASTING

A.MANNESMANN A MEMBER OF
SCHNEEBERGER LINEAR TECHNOLOGY

CZECH REPUBLIC

SCHNEEBERGER
Mineralgusstechnik s.r.o
Prumyslový park 32/20
350 02 Cheb – Dolní Dvory

+420 354 400 941
+420 354 400 940
info-mineralguss@schneeberger.com

CHINA

SCHNEEBERGER Changzhou
Precision Systems Co. Ltd.
137 Hanjiang Road
Changzhou New district
213000 Changzhou, Jiangsu

施耐博格 (常州) 测试系统有限公司
汉江路137, 常州新区, 常州213022

+86 519 8988 3938
+86 519 8988 5115
info-mineralcasting@schneeberger.com

GERMANY

A.MANNESMANN
MASCHINENFABRIK GmbH
Blüdinghauser Str. 27
42859 Remscheid

+49 2191 989-0
+49 2191 989-201
mail@amannesmann.de

SCHNEEBERGER SALES DEPARTMENTS

AUSTRIA AND
SOUTH EAST EUROPE

+43 676 935 1035
info-a@schneeberger.com

BENELUX

+31 6 5326 3929
info-nl@schneeberger.com

DENMARK, SWEDEN

+31 6 5326 3929
info-nl@schneeberger.com

FRANCE

+33 6 33 12 14 26 (West)
+33 7 72 55 06 74 (Ost)
info-f@schneeberger.com

GREAT BRITAIN

+44 77 8814 5645
info-uk@schneeberger.com

ISRAEL

+972 5 0551 7920
info-il@schneeberger.com

POLAND, SLOVAKIA,
CZECH REPUBLIC

+420 6 0278 4077
info-cz@schneeberger.com

RUSSIA, BELARUS,
UKRAINE

+7 985 960 85 53
+38 050 407 6789
+37 529 860 0410
info-ru@schneeberger.com

SPAIN, PORTUGAL,
ANDORRA

+34 69 559 05 99
info-es@schneeberger.com

PROSPECTUSES

- COMPANY BROCHURE
- CUSTOMIZED BEARINGS
- GEAR RACKS
- LINEAR BEARINGS AND RECIRCULATING UNITS
- MINERAL CASTING SCHNEEBERGER
- MINISLIDE MSQSCALE

- MINI-X MINIRAIL / MINISCALE PLUS / MINISLIDE
- MONORAIL AND AMS PROFILED LINEAR GUIDEWAYS WITH INTEGRATED MEASURING SYSTEM
- MONORAIL AND AMS APPLICATION CATALOG
- POSITIONING SYSTEMS
- SLIDES

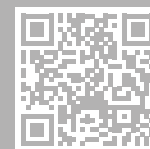

www.schneeberger.com